

CFLG – Type B (No Flange) Computer Room Floor Grilles

Type B Computer room floor grilles are the traditional format computer room floor grilles, which M & M Access Ltd have updated using a new reinforcing extrusion. This enables the new grille to be lighter yet stronger, bringing it into line with today's exacting standards, while making installation easier.

Construction: Extruded aluminium frame and 6.00mm wide blades.

Manufactured using self tapping screws

Expanded and reinforced core.

Options & Accessories: M & M Access Ltd can supply a standard Type B Computer room floor grille or a customised grille made to your exact specifications.



Opposed Blade Damper – Aluminium OBD operated via key/screwdriver, access possible through blades. Please note that this is not a shut off damper and only enables balancing of the air system.

Blanking Plate – Blanking plates enable a portion or the entire grille to be disabled. For instance if aesthetics demand that there be a row of grilles, yet only half will be used for air movement, the other half can be blanked to accommodate this.

Feet – Feet of any size can be fitted to computer room floor grilles. These enable the grille to be mounted flush to whatever floor tile is being fitted around it.

Installation

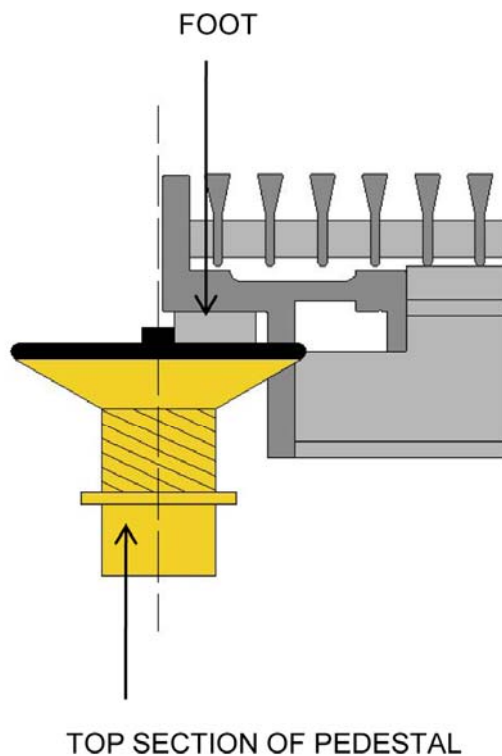

All Computer room floor grilles are designed to be laid into a prepared raised access floor, therefore installation simply involves laying the grille into position.

If the grille has feet then the feet simply butt up against the raised section of the pedestal top.

Technical Information

- Free area – Approx 33%
- CFLG TYPE B – 600 x 600 O/A Mass – 11.25 KG
- CFLG TYPE B/D – 600 x 600 O/A Mass – 13.00 KG
- 600 x 600 O/A - CFLG Type B

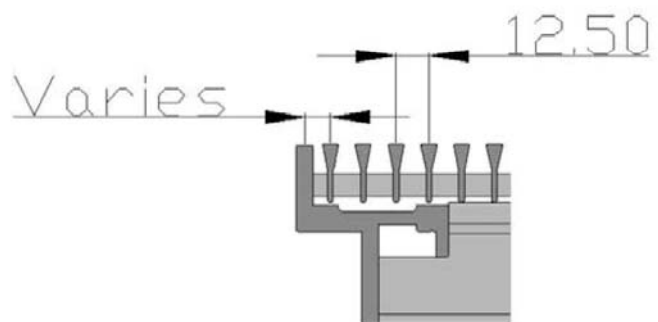
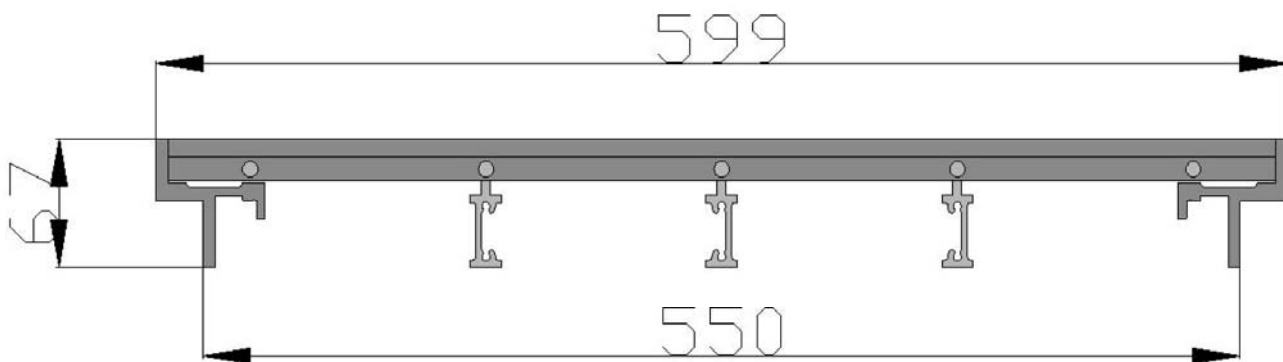
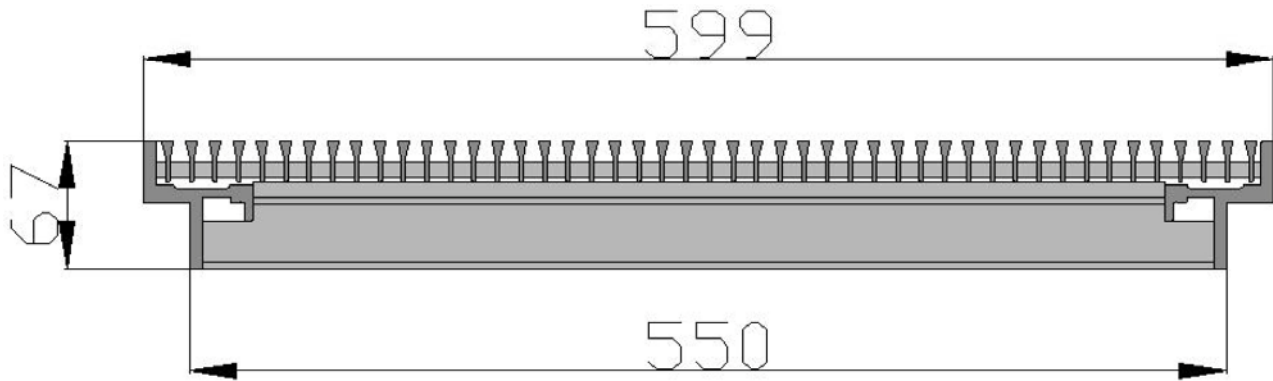

Distance between outermost blade and frame is variable based on size. On a standard 600 x 600 O/A this gap is approximately 2.00mm.

• 600 x 600 O/A - CFLG Type B - D

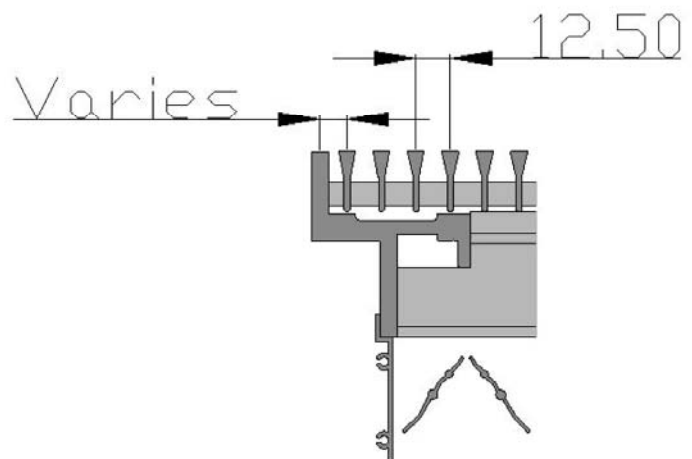
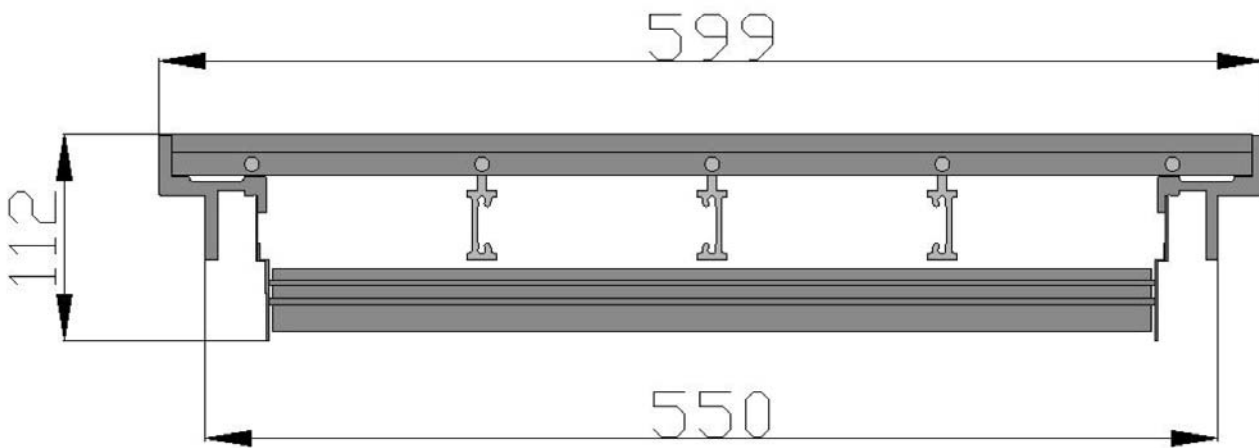
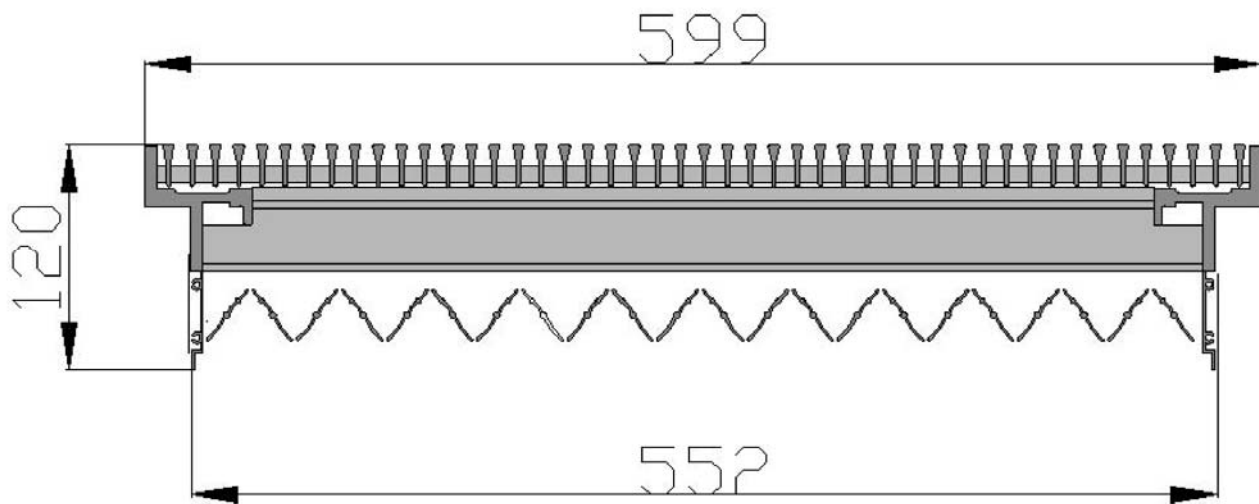

Distance between outermost blade and frame is variable based on size. On a standard 600 x 600 O/A this gap is approximately 2.00mm.

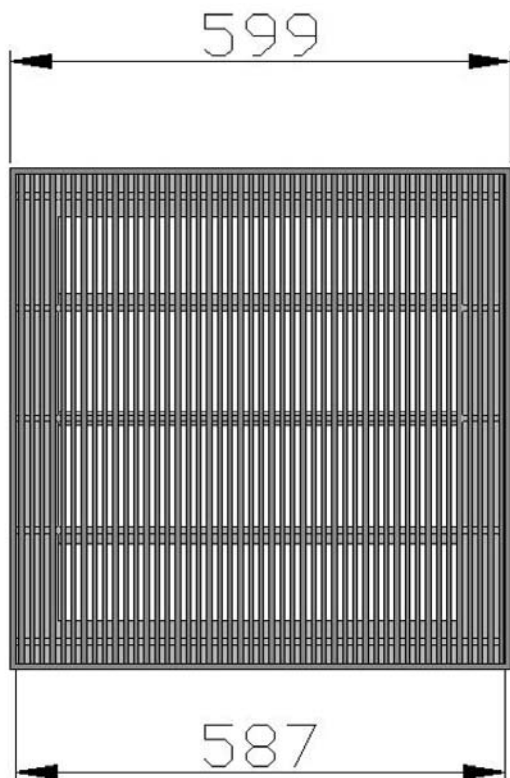

Type B Computer room floor grilles are suitable for all raised access flooring types and are also fully compatible with stringers.

Grille Size - 600 x 600 Overall		Air Volume M ³ /S						
		0.20	0.25	0.35	0.45	0.55	0.75	0.90
SUPPLY	Noise (NR)	21	21	22	23	24	25	
	Throw (m)	3	3.50	4	4.50	5	6	
	Pressure Drop (Pa)	2	2.50	3.50	5.50	7.50	12	
EXTRACT	Noise (NR)	21	22	25	27	29	33	35
	Pressure Drop (Pa)	3	5	7	10	14	24	33

- NR ratings are based on dampers fitted in fully open position.
- Increase pressure drops where dampers are fitted by 50%.
- Do not exceed 1m³/s volume, or 2.5m/s face velocity per 600 x 600 unit.

M & M Access Ltd
5 Quarry Park Close
Moulton Park Industrial Estate
Northampton
NN3 6QB
Tel: 01604 644944 Fax: 01604 644899

Email: sales@m-maccess.co.uk

Web: www.m-maccess.co.uk / www.access-panels.com